

Aquor® House Hydrant V2+

IN-WALL OUTDOOR FAUCET SYSTEM

FLUSH-MOUNT | QUICK-CONNECT | SELF-DRAINING | ANTI-SIPHON | NON-FREEZE



aquor
water systems



AQUOR® HOUSE HYDRANT V2+

VBHP-SERIES

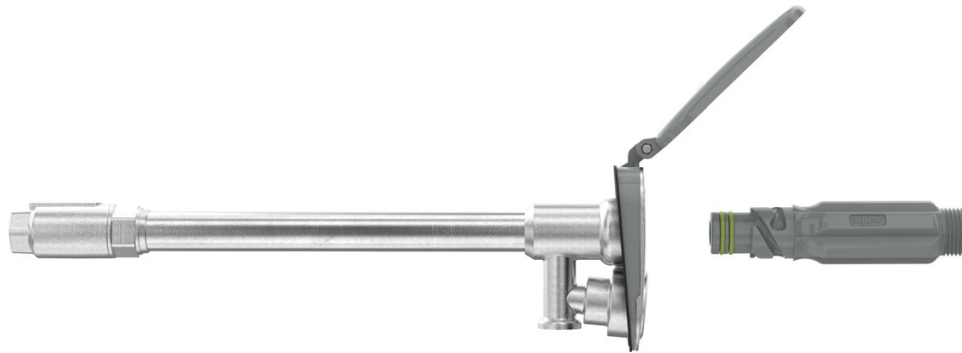

AQUOR® HOUSE HYDRANT V2+: WALL HYDRANT / FREEZELESS SILLCOCK

Freezeless sillcock for exterior building walls.

Instant Water Access

Less than a second to connect. Garden hoses can be quickly engaged under full pressure, hassle-free. Water flow starts instantly.

No Leaks, No Maintenance

The pressure-closed valve minimizes wear and cannot be overtightened, for an extremely long lifespan even with frequent use.

Sub-Zero Freeze Protection

Just unplug and go. The stainless steel body provides significantly more freeze protection than traditional brass frost-free sillcocks.

Low-Profile Design

Sits flush against the wall for a sleek appearance. Saves valuable inches on walkways and tight spaces, and prevents snagging hazards.

Marine-Proven Reliability

An industrial-use connection system backed with over 15 years of testing and development for harsh marine environments.

Heavy-Duty Hose Connector

Durable, wear-resistant, and crushproof, the commercial-grade hose connector attaches to any standard garden hose.

100% Lead-Free Stainless Steel

Our marine-grade, low-carbon stainless steel is vacuum-cast for maximum strength and durability. Absolutely zero lead is used.

High-Performance O-Rings

Viton® O-rings are renowned for their long lifespans and wear resistance.

AQUOR® HOUSE HYDRANT V2+

VBHP-SERIES

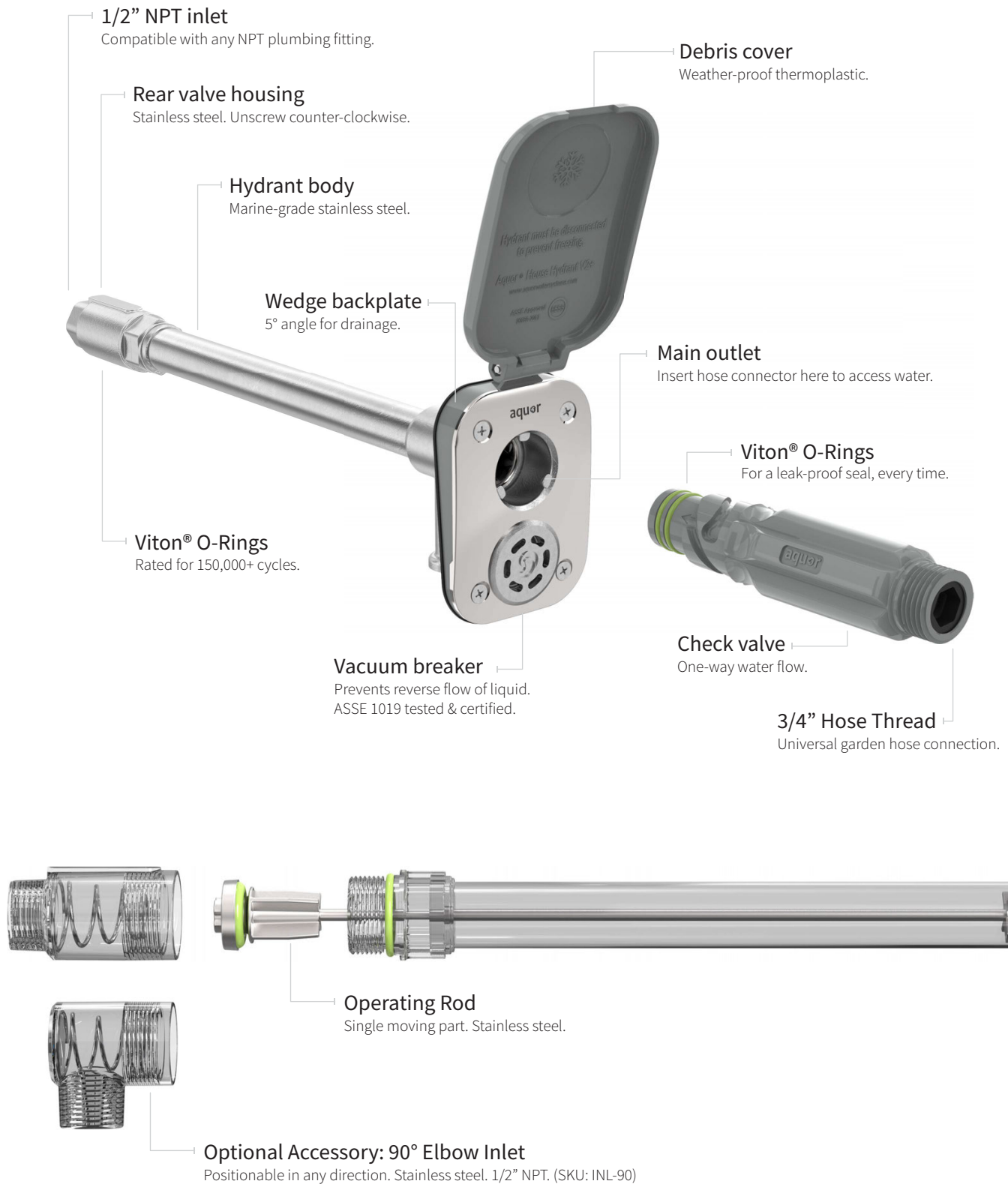

AQUOR® HOUSE HYDRANT V2+

VBHP-SERIES

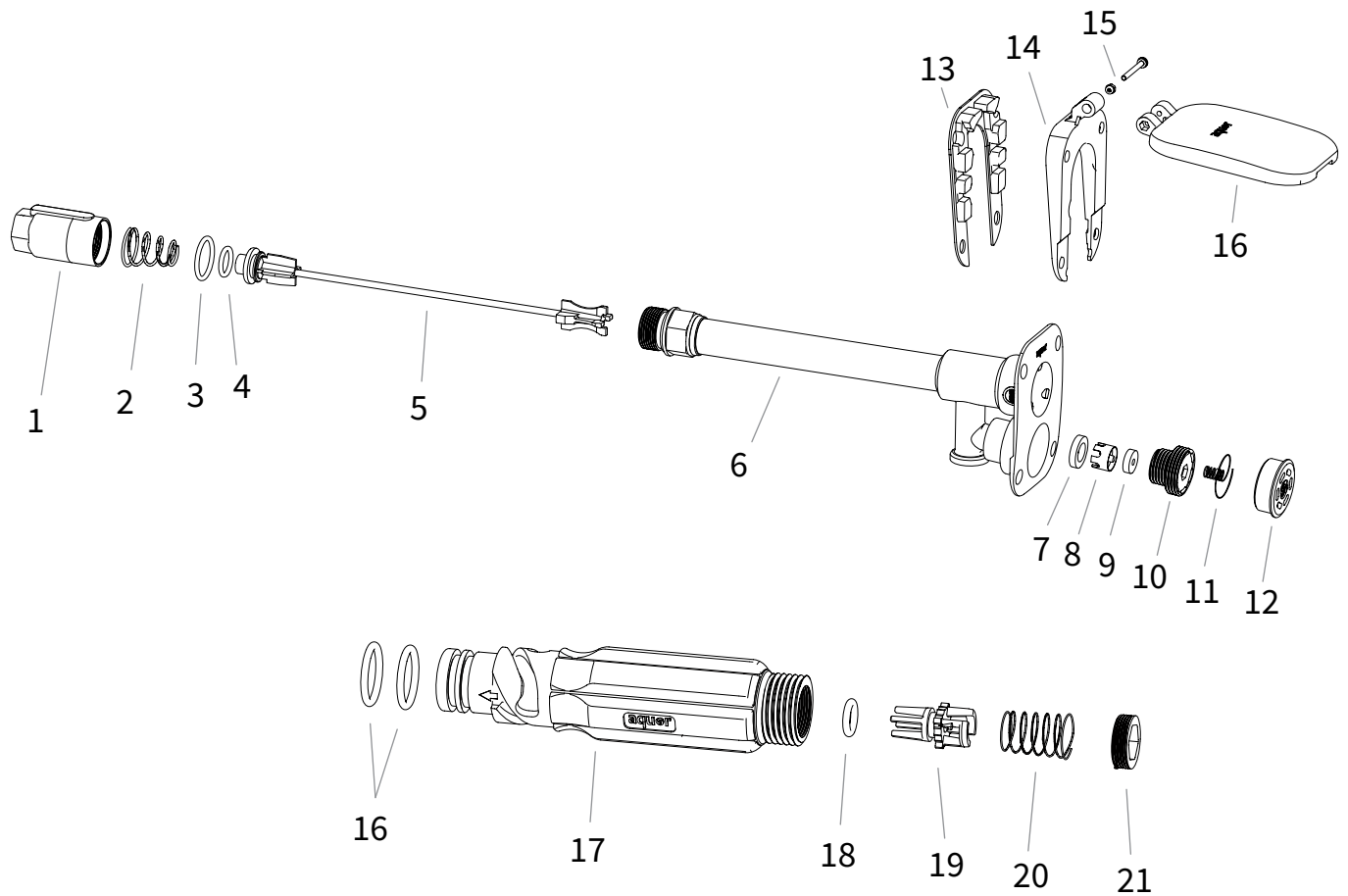

PART DESCRIPTIONS

- | | |
|--------------------------------------|---------------------------------|
| 1. Rear Valve Housing (inlet) | 16. Connector O-Rings |
| 2. Valve Spring | 17. Connector Body |
| 3. Hydrant Body O-Ring | 18. Check Valve O-Ring |
| 4. Inner Valve O-Ring | 19. Check Valve |
| 5. Operating Rod | 20. Check Valve Spring |
| 6. Hydrant Body | 21. Check Valve Retainer |
| 7. Vacuum Breaker Washer | |
| 8. Vacuum Breaker Valve | |
| 9. Vacuum Breaker Seal | |
| 10. Vacuum Breaker Retainer | |
| 11. Vacuum Breaker Spring | |
| 12. Vacuum Breaker Cover | |
| 13. Debris Cover Gasket | |
| 14. Debris Cover Wedge | |
| 15. Debris Cover Nut & Bolt | |
| 16. Debris Cover | |

Need parts?

Spare and replacement parts are readily available for every product we make.

contact@aquorwatersystems.com

AQUOR® HOUSE HYDRANT V2+

VBHP-SERIES

FREEZELESS OUTDOOR FAUCET SYSTEM

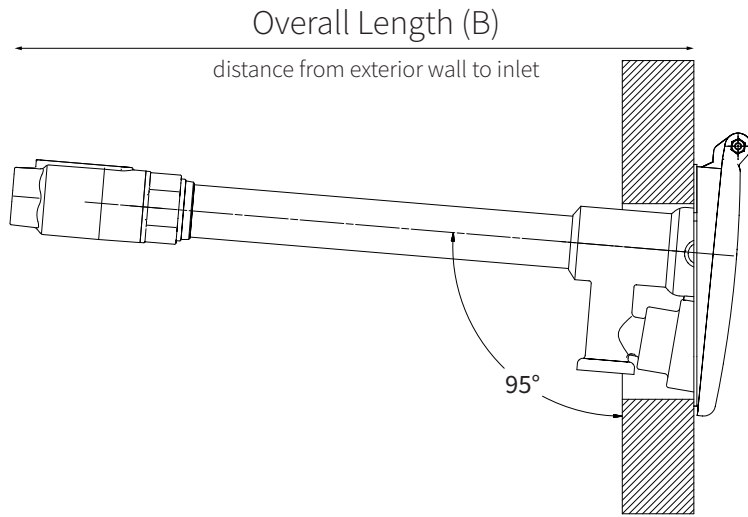

Flush-mounted wall hydrant with twist-lock connection system. Integral vacuum breaker for anti-siphon protection.

- Allows user to access water instantly by connecting under full water pressure.
- Robust O-ring connection system ensures a reliable leak-proof seal, even at high water pressures.
- Stainless steel operating rod and pressure-closed valve provide zero-maintenance reliability for years.
- Hydrant self-drains upon disconnection to provide freeze protection.
- Hydrant comes standard with 1/2" female NPT inlet. Rotatable 90° elbow and other inlets available.
- Each hydrant kit includes polymer hose connector with 3/4" GHT threading.
- Any 3/4" accessory (eg. water timers, splitters, regulators) can be attached to end of hose connector.
- Hose connector contains integral check valve for additional backflow protection.

- Inlet/Outlet: 1/2" NPT, 3/4" GHT
- Flow rate: 6.8 GPM @ 52 PSI
- Operating water pressure: 25 - 125 PSI
- Operating temperature range: 33° - 140° F
- Approvals: ASSE 1019A
- Warranty: 10-year stainless components, 5-year polymer

SKU	(A) STEM	(B) OVERALL LENGTH
<input type="checkbox"/> VBHP002	Close-Couple Hydrant	4 1/2" 115mm
<input type="checkbox"/> VBHP004	4" Hydrant	5 9/16" 143mm
<input type="checkbox"/> VBHP006	6" Hydrant	7 9/16" 193mm
<input type="checkbox"/> VBHP008	8" Hydrant	9 1/2" 243mm
<input type="checkbox"/> VBHP010	10" Hydrant	11 1/2" 292mm
<input type="checkbox"/> VBHP012	12" Hydrant	13 1/2" 343mm

• Note: optional 90° elbow inlet reduces total length by 1/2" [13mm]

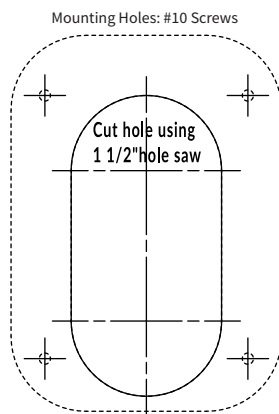

Using a 1.5" hole saw is suggested. You may also cut a rectangular hole.

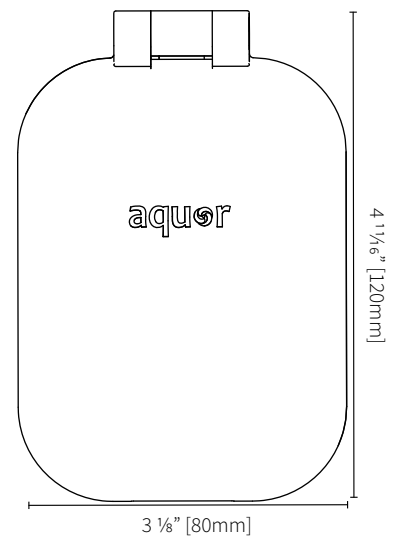
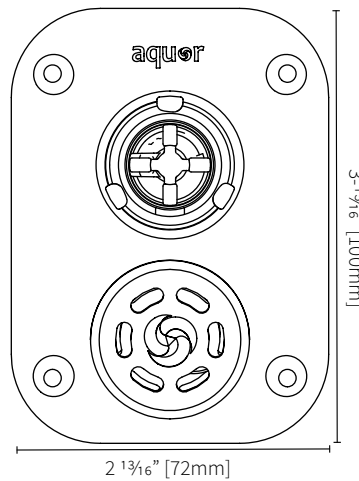

AQUOR® HOUSE HYDRANT V2+

VBHP-SERIES

VBHP-002

CLOSE-COUPLE HOUSE HYDRANT V2+

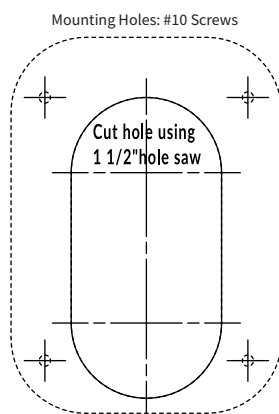
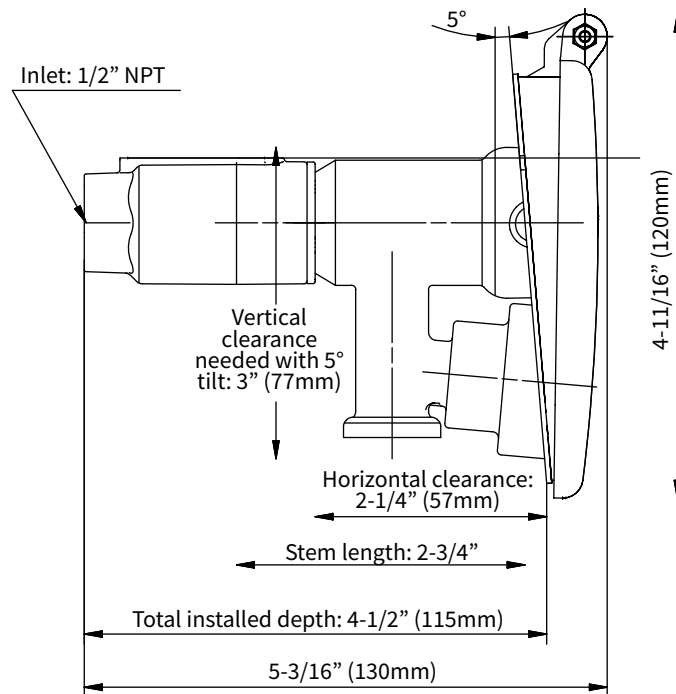

Using a 1.5" hole saw is suggested. You may also cut a rectangular hole.

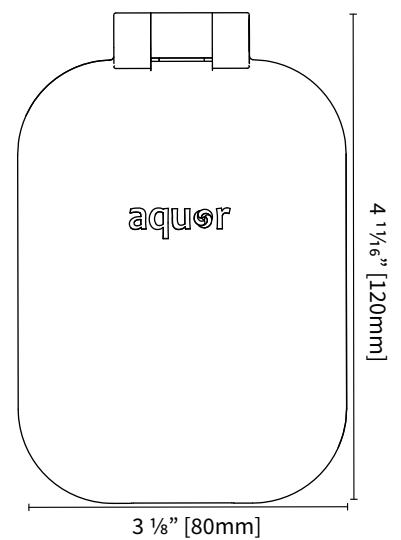
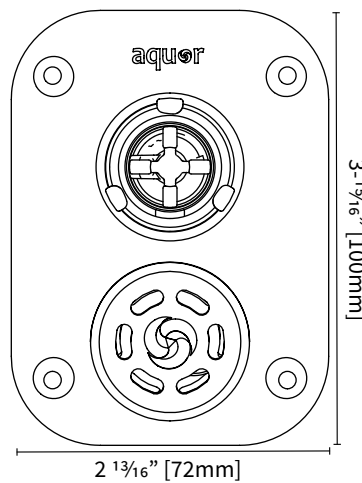

AQUOR® HOUSE HYDRANT V2+

VBHP-SERIES

VBHP-004

4" HOUSE HYDRANT V2+

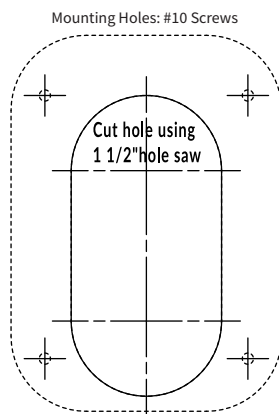
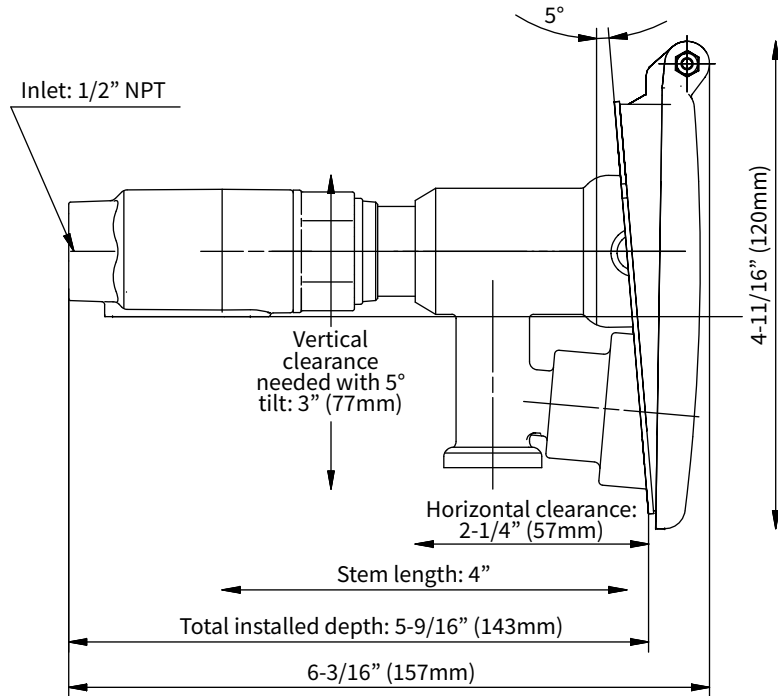

Using a 1.5" hole saw is suggested. You may also cut a rectangular hole.

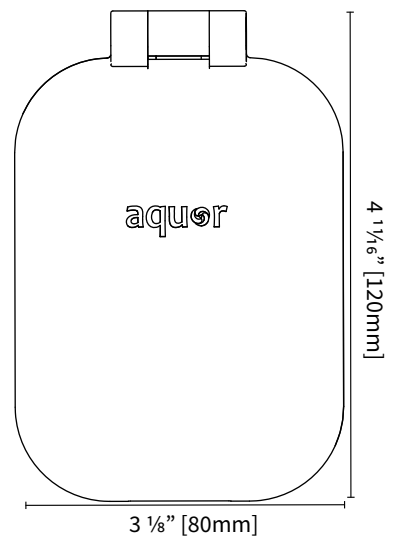
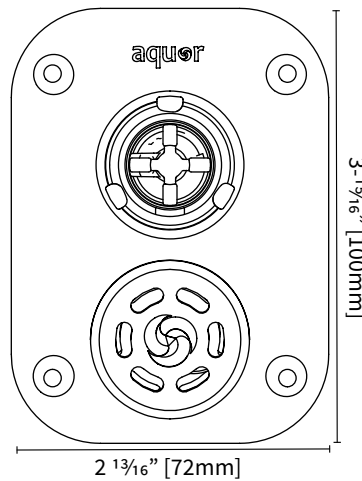

AQUOR® HOUSE HYDRANT V2+

VBHP-SERIES

VBHP-006

6" HOUSE HYDRANT V2+

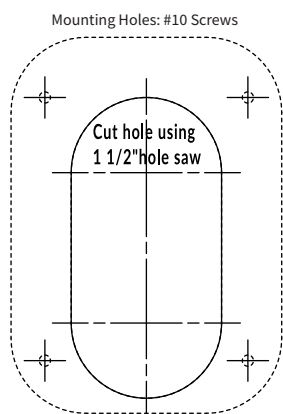
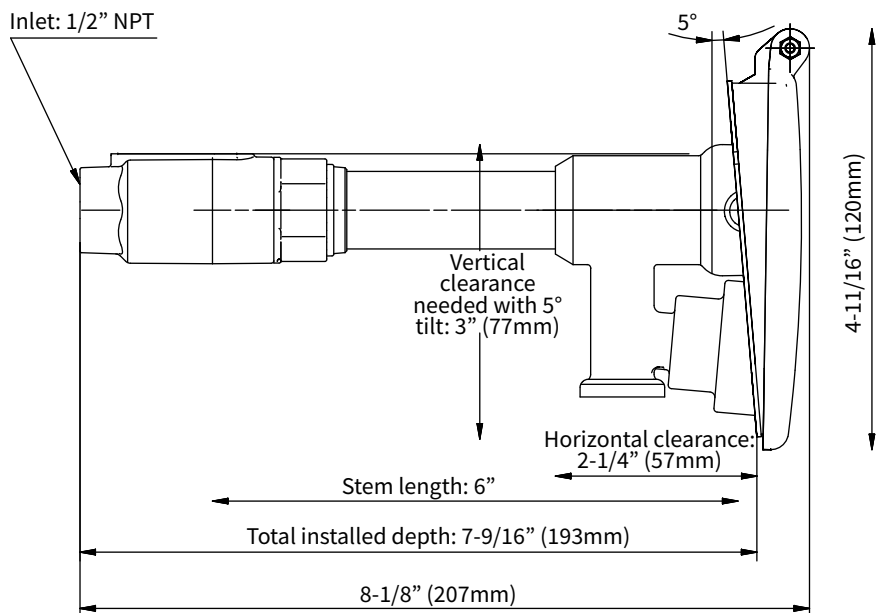

Using a 1.5" hole saw is suggested. You may also cut a rectangular hole.

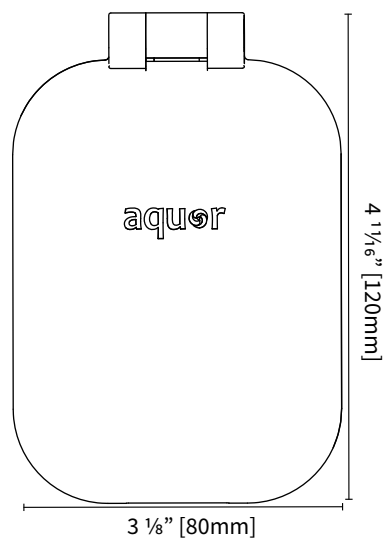
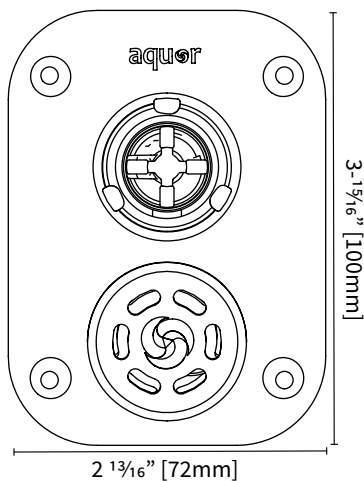

AQUOR® HOUSE HYDRANT V2+

VBHP-SERIES

VBHP-008

8" HOUSE HYDRANT V2+

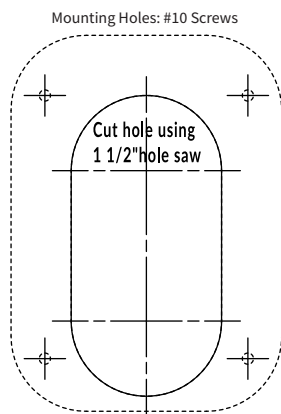
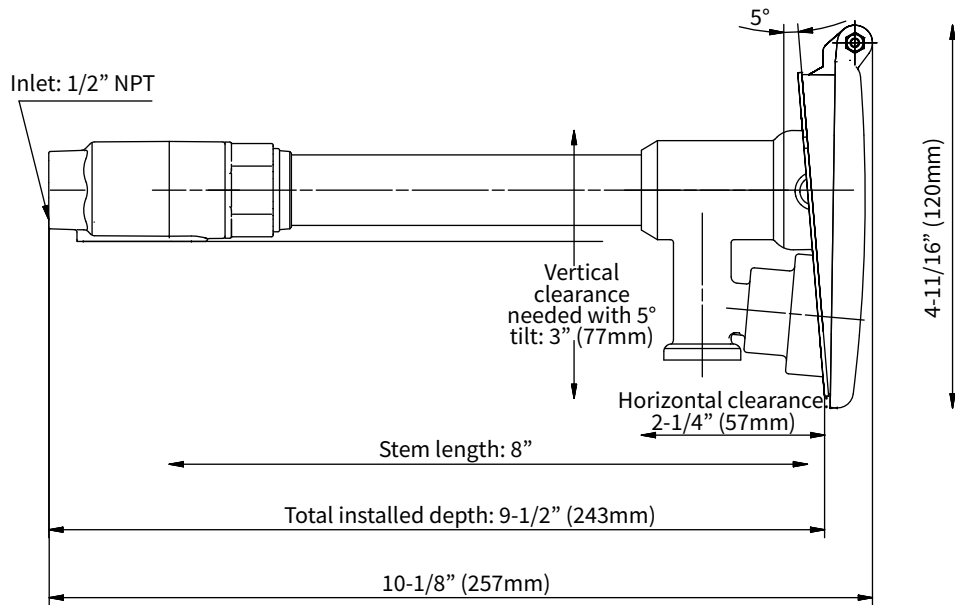

Using a 1.5" hole saw is suggested. You may also cut a rectangular hole.

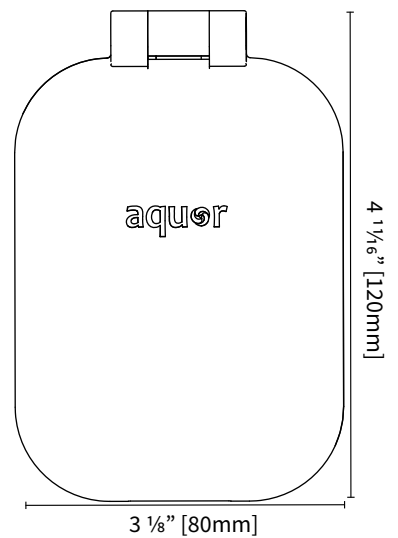
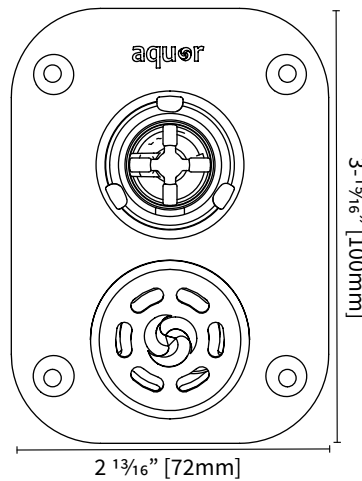

AQUOR® HOUSE HYDRANT V2+

VBHP-SERIES

VBHP-010

10" HOUSE HYDRANT V2+

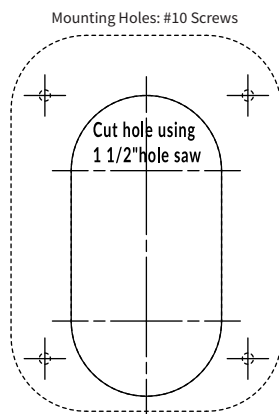
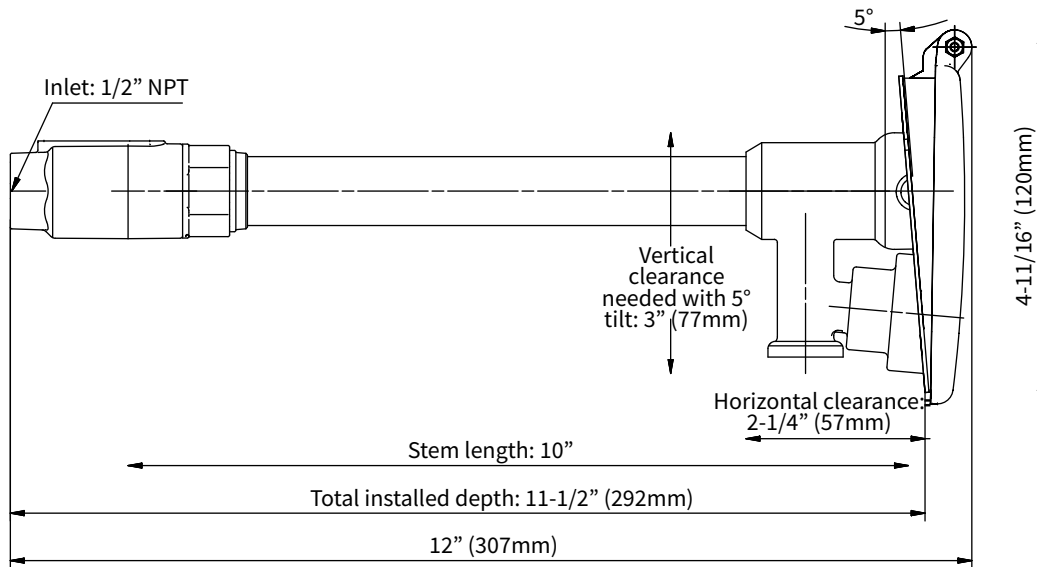

Using a 1.5" hole saw is suggested. You may also cut a rectangular hole.

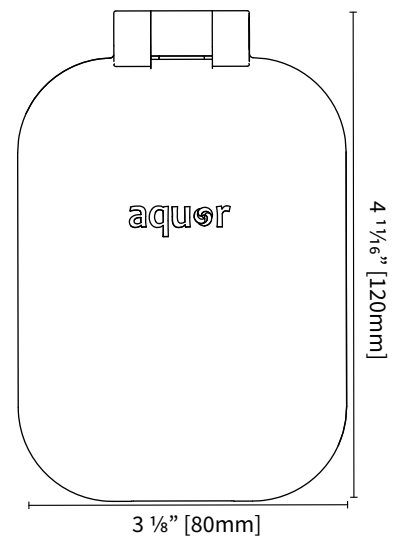
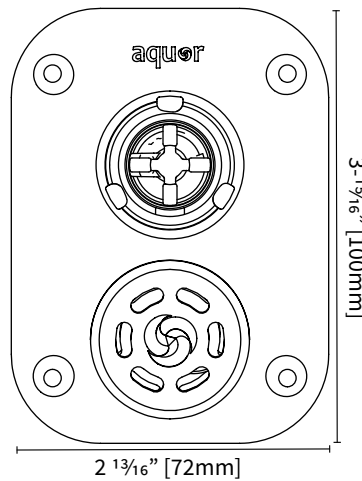

AQUOR® HOUSE HYDRANT V2+

VBHP-SERIES

VBHP-012

12" HOUSE HYDRANT V2+

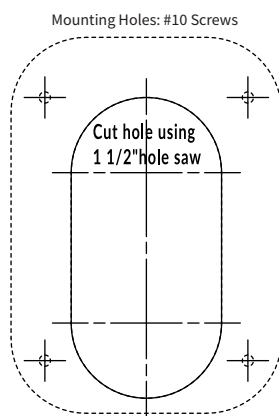
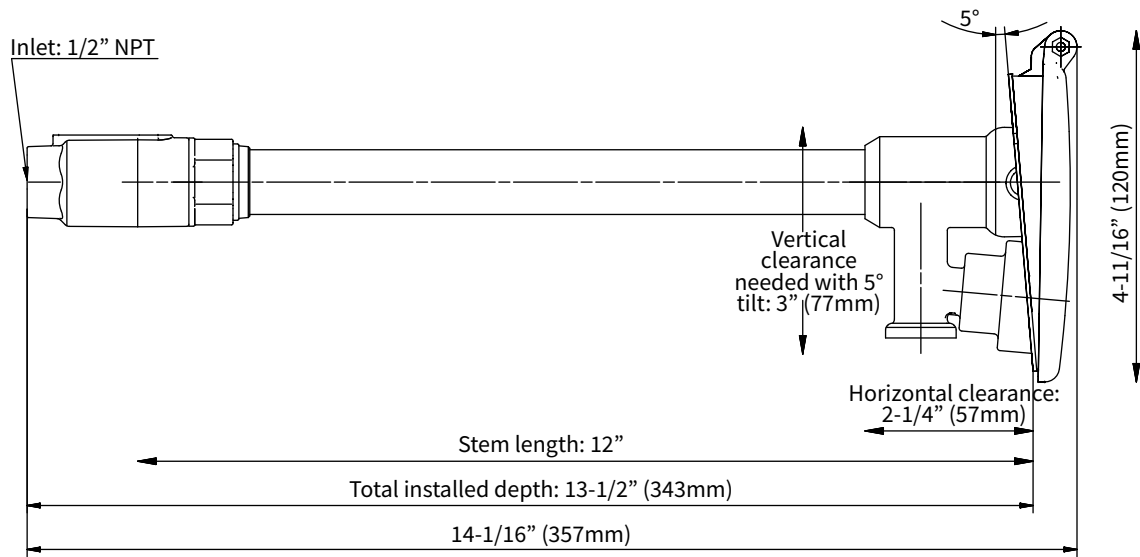

Using a 1.5" hole saw is suggested. You may also cut a rectangular hole.

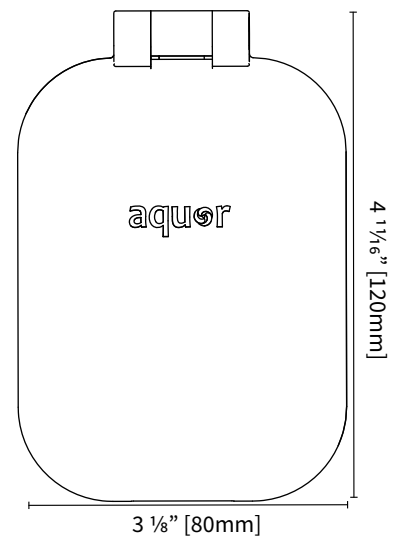
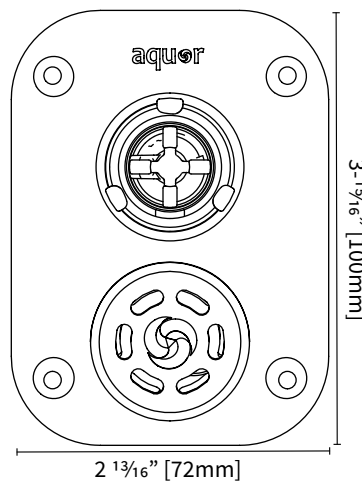

AQUOR® HOUSE HYDRANT V2+

Installation

The Aquor House Hydrant is designed for outdoor use. Install in exterior walls of homes and buildings. A small amount of water self-drains from the outlet upon disconnection.

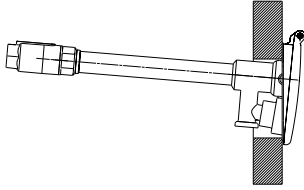

If you are installing the hydrant on a surface that isn't flat or smooth, such as stucco, masonry, or lap siding, using a mounting block is highly recommended. Use flashing to protect against water intrusion.

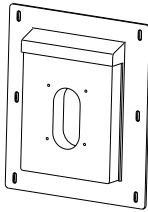

Use the template (included in hydrant box) to drill the entry hole. 1-1/2" bit size recommended.

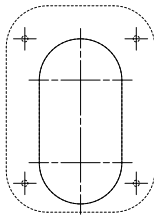

You can unscrew the rear inlet from the main hydrant body. Thread in the appropriate 1/2" NPT fitting for your plumbing, wrapped in teflon tape then pipe-joint compound. Re-attach the inlet and tighten. Hand-tight is fine, do not over-torque. The inlet is designed to rotate 360° from full lock for alignment, while still keeping a watertight seal.

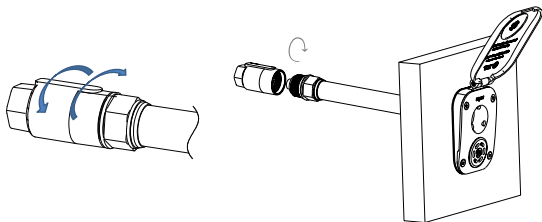

The House Hydrant is for heated and insulated building walls only. The House Hydrant can only offer freeze protection if the ambient temperature around the rear valve is above freezing.

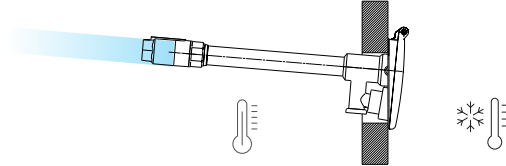

A mounting block provides a level, 90° surface that allows the hydrant faceplate to sit tightly against the wall. The hydrant's cover backplate provides a 5° downward tilt for drainage.

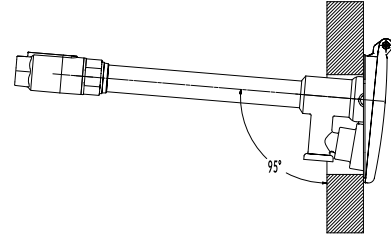

For the mounting holes, make sure to insert the debris cover and wedge behind the hydrant faceplate for accurate markings.

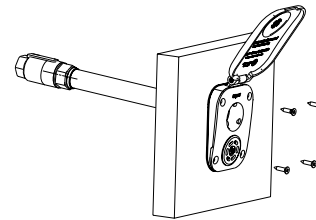

With the appropriate fitting threaded in, connect the hydrant to your plumbing system. With PEX tubing, we recommend adding an expansion loop inside the wall if possible. This allows the hydrant and fitting to be inspected and serviced from the exterior of the building, if ever needed.

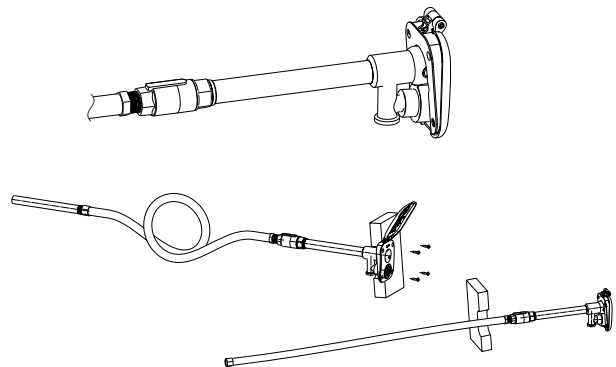

AQUOR® HOUSE HYDRANT V2+

Hose Connector

Attach the Aquor® hose connector to any garden hose. It can stay attached; there is no need to remove it every use. Before storage, de-pressurize your hose by squeezing the nozzle on the other end.

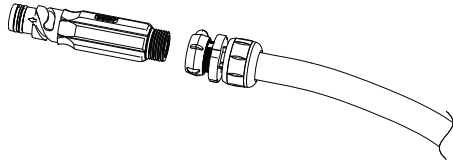

Use any accessory as you would with a traditional bibb. Inline ball valves, timers, splitters, vacuum breakers, and etc. can be attached to the connector.

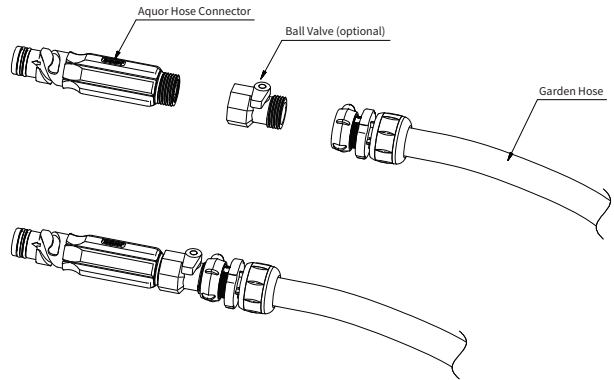

Operation

To engage, line up the three helical grooves on the hose connector (marked with an arrow) with the three nibs on the hydrant faceplate. Simultaneously push and twist the connector clockwise in a smooth motion. Water flow will start instantly when the connector is engaged.

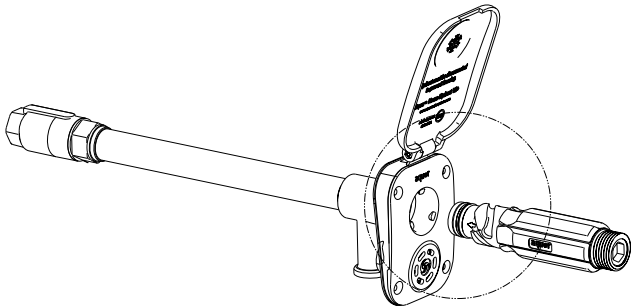

To disconnect, push the connector in slightly, then untwist counter-clockwise. The hydrant will self-drain any remaining water left in the body and vacuum breaker assembly. Remember to de-pressurize your hose before storage.

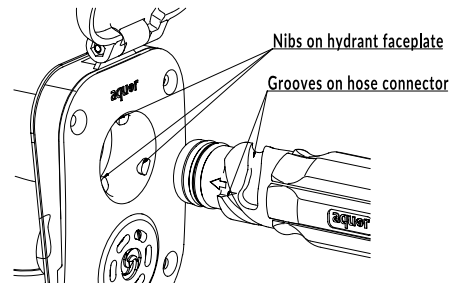

Bayonet locking design keeps connector secure when engaged

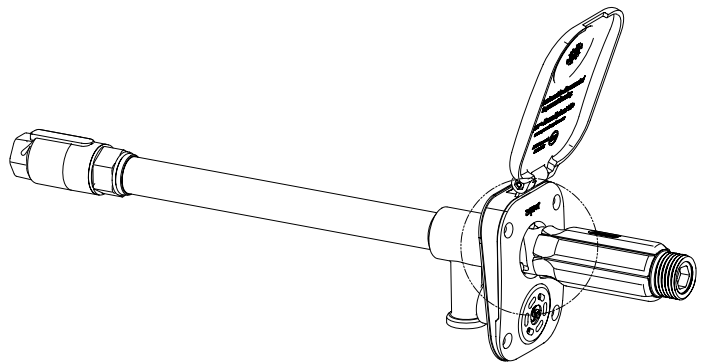
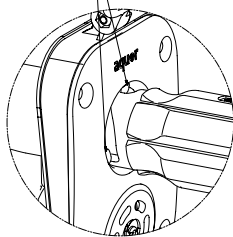

AQUOR® HOUSE HYDRANT V2+

Care & Maintenance

It's best to disconnect the hydrant when not in use. The hydrant can only offer freeze protection when disconnected. We recommend unplugging after each use.

Storing your hose connectors out of the elements can prolong their lifespan. You can drain your hose and bring it inside - the internal check valve prevents any unwanted draining afterwards, so your floor stays dry.

Routine cleaning with soap and water is usually sufficient to maintain the corrosion resistance and appearance of the marine-grade stainless steel. Use a soft brush to remove any accumulated dirt, then rinse with clean water. Use stainless steel polish as needed.

If you leave the Aquor connector attached to your garden hose, make sure to de-pressurize the hose after use. Temperature changes can cause water inside to expand, causing excessive pressure on the connector's internal check valve (and your nozzle or accessories) over time.

Protect the hose connector's O-rings. They are designed for extremely long lifespans if used properly. Use care not to snag the connector O-rings on the hydrant nibs. When connecting, line up the grooves before attempting to push or twist.

If you have hard water buildup, the hydrant can be completely disassembled for service or cleaning if needed. The inner valve and stem are accessed through the rear. Adding a service loop of PEX during installation makes this easy in the future.

Troubleshooting

No water flow when connected. Check to make sure water supply is live to the hydrant. If water supply is active, the connector's internal check valve may be stuck. It can be accessed through the threaded end of connector. Or, insert a long screwdriver into the front end and firmly tap down.



Correct order of check valve assembly

Water leaking from hydrant body. Inspect the O-ring between the rear valve housing (threaded inlet) and hydrant main body. The rear valve housing does not need to be firmly tightened; it should remain leak-free up to a full revolution from lock.

Water leaking from vacuum breaker. Unscrew the colored vacuum breaker cap, then test hydrant. If the leak stops with cap removed, the inner spring may be too heavy for the water pressure. If the leak continues, disconnect and unscrew the white polymer retainer. Ensure all vacuum breaker parts are present and in the correct order as shown below.

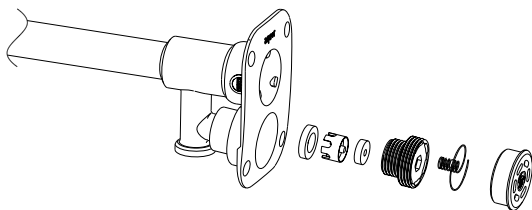

Correct order of vacuum breaker assembly

Water leaking from hydrant inlet. If leaking from the plumbing connection, ensure a proper 1/2" NPT fitting was used. Use 4-5 wraps of teflon tape, followed by a layer of pipe-joint compound.

Water leaking from hydrant outlet. If leaking while disconnected, unscrew the rear valve housing, check for debris, and inspect inner valve O-ring for damage. If leaking while connected, inspect both hose connector O-rings for damage.

Water sprays from vacuum breaker when connecting. Unscrew vacuum breaker cap and test again. The inner spring may be too heavy for the water pressure. If the issue persists, inspect the vacuum breaker washer and replace if needed.

Hose connector won't stay plugged in. The hydrant uses water pressure to seal, and is designed for pressures of 25-125 psi. If you are installing the hydrant on a well or low-pressure system, contact us for a higher weight internal spring.

Hose connector won't unplug. If the hose connector seems stuck or requires too much effort to unplug, there may be pressure or suction holding it in. Try squeezing your hose nozzle while disconnecting. If the issue occurs gradually, try cleaning the hydrant outlet and lubricating O-rings with petroleum jelly.

Support & Warranty

We stand behind every product we make. Our mission is to manufacture the highest-quality water connectors possible, and our products are engineered to last years of frequent use.

Aquor offers a 10 year warranty on all stainless steel components, and 5 years on all polymer components. For more information, contact us or visit our website at www.aquorwatersystems.com.